

Installation Instructions for 60542 Mustang Torque Box Reinforcements

Installation Instructions for Lower Control Arm Torque Box:

1. With front wheels securely blocked, raise rear of vehicle to an adequate working height. Support chassis securely with jack stands.
2. Slowly lower differential as low as possible (*Be careful not to over extend factory rubber brake lines*) and support securely with jack stands.
3. While supporting the front of the lower control arm with a floor jack, remove the lower control arm front bolt.
4. Remove the lower rear seat cushion and scrape away any sound deadening material from the torque box area.
5. On 1994-2004 Mustangs: From inside the vehicle disconnect the ABS harness connector that leads down through the torque box and temporarily remove the ABS harness and bracket from the torque box under the vehicle.
6. There are a left and right side torque box reinforcement plate, verify which plate is correct for the side of the vehicle you're working with. See illustration below.
7. Place the torque box reinforcement bracket up into the vehicles torque box. The side with four(4) holes will go up against the floor board. On 1979-1993, the opening in the chassis should be large enough. On 1994-2004 the vehicles torque box opening will require them to be trimmed back.
8. Re-install lower control arm bolt through control arm and into the large hole in the torque box reinforcement bracket and torque to manufacturer's specifications. See Figure 1.
9. Using a 3/8" drill bit, from underneath the car, drill through the four(4) 3/8" holes in the top of the torque box reinforcement plate up through the body of the vehicle.
10. On 1994-2004, from inside the vehicle, drill a hole for the ABS sensor harness the same size as the OEM hole down through the top of the reinforcement plate.
11. From inside the vehicle line up the 6"x6" support plate with the four(4) holes drilled in the previous step and using the supplied hardware to install and tighten all bolts. See Figure 1.
12. If welding, remove all paint, dirt & oil from the surface with a grinder or sander and weld in place. Repaint the welded area with a rust prohibitive coating.
13. On 1994-2004, from under the vehicle, drill a hole for the ABS sensor harness the same size as the OEM hole up through the support plate.
14. Re-install ABS harness and bracket.
15. Repeat on other side.

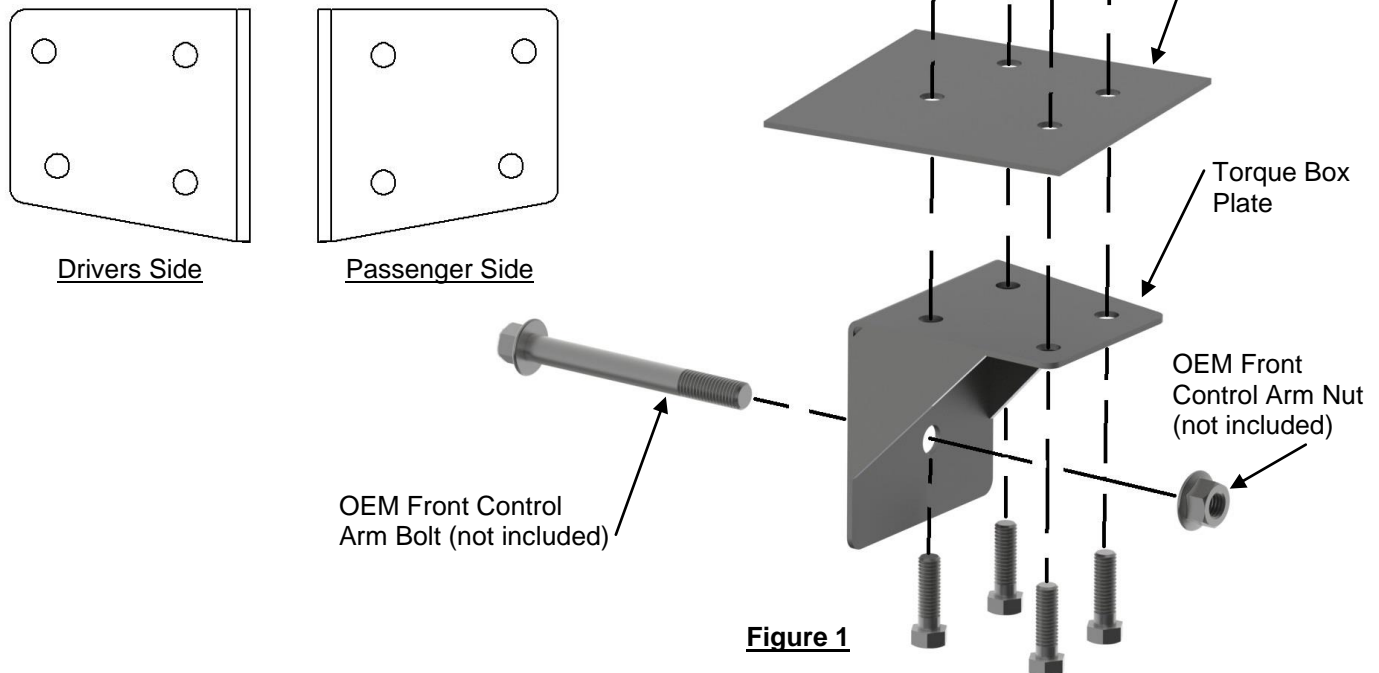

Installation Instructions for Upper Control Arm Torque Box:

1. With front wheels securely blocked, raise rear of vehicle to an adequate working height. Support chassis securely with jack stands.
2. Slowly lower differential as low as possible (*Be careful not to over extend factory rubber brake lines*) and support securely with jack stands.
3. Continue supporting the differential with a floor jack; remove the upper control arm front bolt.
4. Remove both sections of the rear seat and scrape away any sound deadening material from the upper torque box area where the curved plates will sit.
5. From under the vehicle, drill a 1/2" hole at a 90° angle straight up through the forward most 1/2" hole in the top of the upper torque box and through the inner floor pan. See Figure 2.
6. There are a left and right side torque box reinforcement plate, verify which plate is correct for the side of the vehicle you're working with. See illustration below.
7. Place the torque box bracket in place and have another person slide a 1/2" bolt up through the bracket while from inside the vehicle you install the appropriate curved plate over the bolt followed by an angled spacer then washer then nut and tighten lightly. See Figure 3.
8. From under the vehicle drill another 1/2" hole at a 90° angle straight up through the rear most 1/2" hole in the top of the upper torque box bracket and through the inner floor pan. See Figure 2.
9. Have another person slide another 1/2" bolt up through the bracket while from inside the vehicle you install another angled spacer then washer then nut and tighten lightly. See Figure 3.
10. Have another person hold the lower part of the curved plate against the body of the vehicle with a 2x4 from inside the vehicle. From under the vehicle drill the two(2) 3/8" holes at the bottom of the bracket and completely through the curved plate. Install the 3/8" bolt and locknut and tighten lightly. See Figure 3.
11. Tighten all bolts.
12. If welding, remove all paint, dirt & oil from the surface with a grinder or sander and weld in place. Repaint the welded area with a rust prohibitive coating.
13. Re-install upper control arm.
14. Repeat on other side.

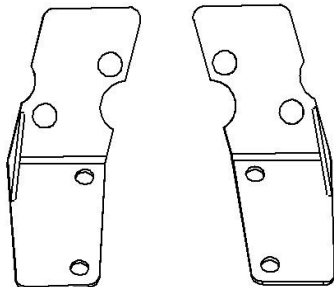

Drivers Side

Passenger Side

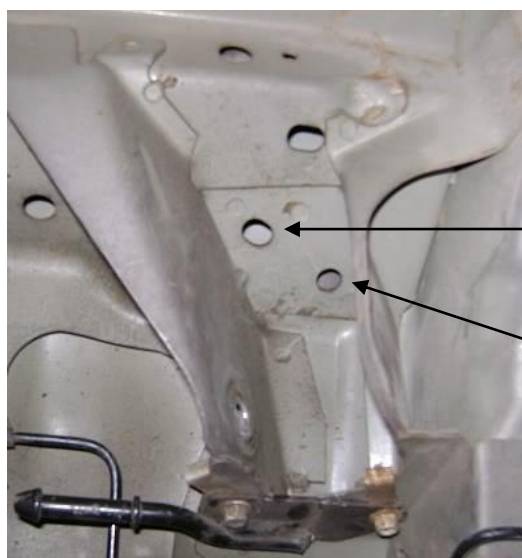

Rear Hole

Forward Hole

Figure 2

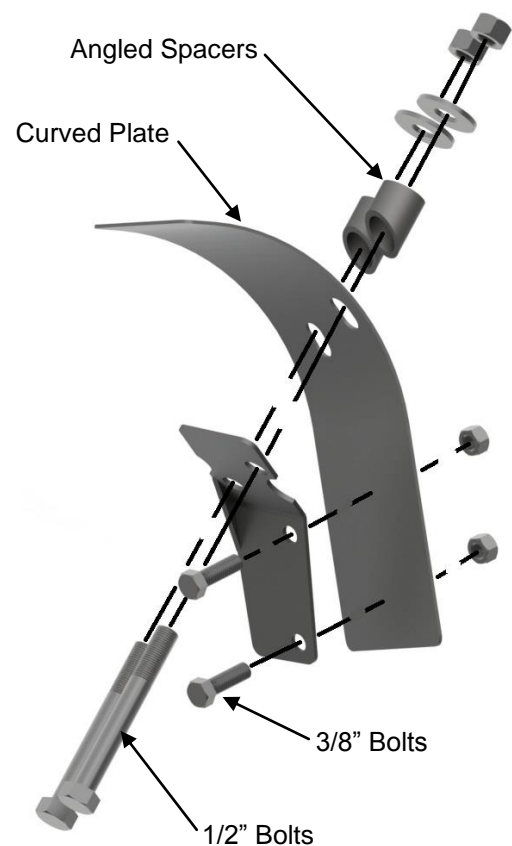

Figure 3