

INSTALLATION INSTRUCTIONS

DISTRIBUTOR CAP - IGNITION COIL REPLACEMENT

Part # 40001 Ignition Coil

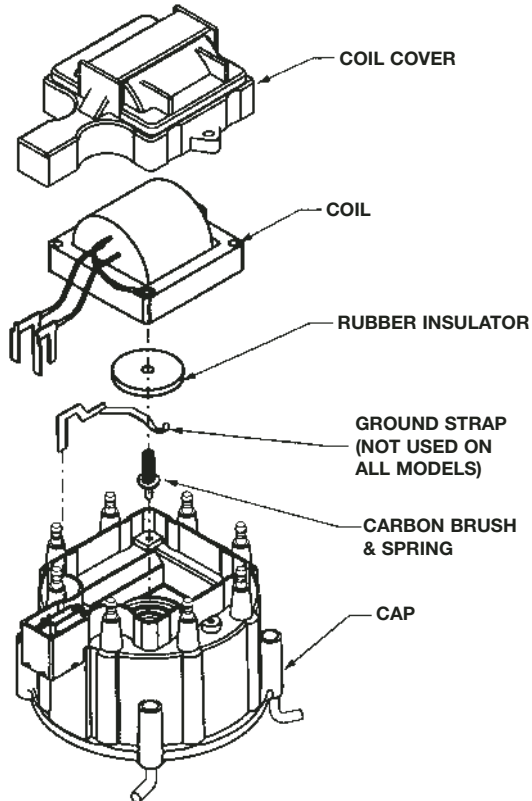

DISTRIBUTOR CAP COMPONENTS

GENERAL INFORMATION

1. Disconnect the feed and module connectors from the distributor cap.
2. Remove the spark plug wire retainer, if so equipped.
3. Remove the coil cover. Retain the screws and cover.
4. Using needle nose pliers, lift the coil leads out of the distributor cap.

IF REPLACING CAP ONLY

1. Depress and twist to release the four distributor cap retaining screws. Remove the cap from the distributor.

2. Install the new carbon brush and spring in the cap. It is recommended to apply silicone grease to the rubber washer for a better seal, then place the washer into position in the cap.
3. Install coil following the above instructions and making sure the leads are in position as indicated in the illustration.
4. Reinstall original coil mounting screws, coil cover, cover retaining screws, and distributor cap on distributor.
5. Reinstall spark plug wires and retaining rings (if applicable) then reconnect feed and module connectors to the distributor cap.

IF REPLACING COIL ONLY

1. Remove and discard the original rubber washer and clean the coil cavity thoroughly.
2. Before installing the new washer, it is recommended to apply silicone dielectric grease to both sides of the washer for a better seal.
3. Place the greased washer into the cleaned cap making sure the carbon brush and spring are in position first, then place the coil in position. Be sure to reinstall ground strap or ground wire.
4. Place coil leads in the cap as shown and reconnect the feed and module connectors to the cap.
5. Reinstall coil cover, wires, and retaining ring if used.

NOTE: TO PREVENT DAMAGE TO THE CAP, USE THE SCREWS PROVIDED WITH THE COIL. TOO LONG SCREWS WILL PUNCTURE CAP CAUSING A SHORT TO GROUND IN THE SECONDARY.

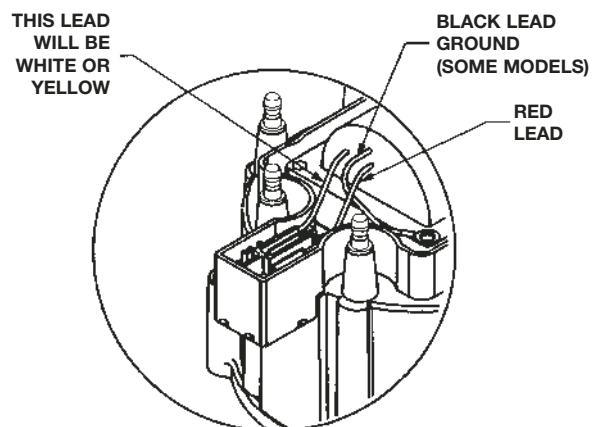

JEG'S
Performance Products

1-800-345-4545 jeps.com